

Focusing on Probable Diagnoses¹

Johan de Kleer

Xerox Palo Alto Research Center
3333 Coyote Hill Road, Palo Alto CA 94304 USA
Email: dekleer@parc.xerox.com

Abstract

Model-based diagnosis is based on first-principles reasoning using the behavioral specifications of the primitive components of a device. Unless the computational architecture of the model-based reasoning engine is carefully designed, combinatorial explosion renders the approach useless for devices consisting of more than a handful of components. This paper analyzes the diverse origins of this combinatorial explosion and outlines strategies to cope with each one. The resulting computational architecture for model-based diagnosis provides orders of magnitude performance improvement on large examples, making model-based approach practical for devices consisting of on the order of 3000 components.

1 Introduction

Model-based diagnosis [2] is a very general approach for diagnosing devices from first principles alone. The GDE [6] and Sherlock [7] systems provide an ATMS-based [3], computational framework for diagnosing multiple faults. Unfortunately, the computational complexity of the algorithms makes them impractical to use for most devices consisting of more than a few dozen components. This paper presents a technique for focusing the processing of these diagnostic engines and the underlying ATMS. By exploiting these techniques both GDE and Sherlock become orders of magnitude more efficient and can easily diagnose devices which were inconceivable to even consider before. For example, they can now diagnose many circuits of over 3000 components in less than a minute of CPU time on a Symbolics XL1200, while without these techniques the same machine runs out of memory in a few hours on the same task. The techniques described in this paper are general and should easily extend to other approaches to model-based diagnosis [12; 14; 15; 18; 19]. The techniques can also be generalized to apply to most-probable-first search in general — although this topic is outside of the scope of this paper.

¹This is a corrected version (as of June 7, 1991) of the paper which appeared in *Proceedings AAAI-91*, Anaheim, CA (1991) 842–848.

Our techniques are based on two fundamental intuitions. The first is to precisely focus the diagnostic reasoning to those sections of the device in which the fault(s) probably lie and to ignore the other parts of the device. The second is to recognize that it is sufficient to identify the most probable diagnoses and to only approximate their probabilities. In particular, it is rarely necessary to find all minimal diagnoses.

2 Example

The intuitions can be illustrated with the faulty n -bit adder illustrated in Figure 1. The ripple-carry adder is a particularly tough example because the carry chain allows signals to propagate through almost every component of the circuit. Suppose all of the inputs are 0 and the output of the n th bit $b_n.Q$ is 1. We have compared the performance of various algorithms on this configuration. The performance of the unfocused GDE degrades very rapidly with n . For example, diagnosing a 4-bit adder already takes 60 seconds. Sherlock, as described in [7], can do a 6-bit adder in the same amount of time. With the techniques presented in this paper, diagnosing a 500 bit adder takes 6 seconds of CPU time! We have run our algorithm on a large number of examples including the circuits provided in a well-known test suite used for evaluating automatic test vector generation programs (ATPG) [1]. However, in order to understand the poor performance of unfocused diagnostic engines we carefully analyze the performance of the algorithm on a family of adders (Figure 1) and parity circuits (Figure 2). This approach gives us a systematic way of creating devices for each size making it much easier to study how performance degrades with size.

If all gates fail with equal likelihood, then, no matter how large the adder is, there are only 5 probable diagnoses (called *leading diagnoses*): $[S1(b_n.X1)]$, $[S1(b_n.X2)]$,

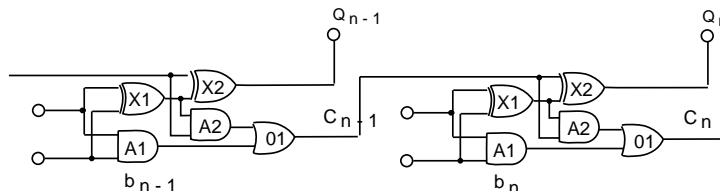

Figure 1: An n -bit ripple carry adder.

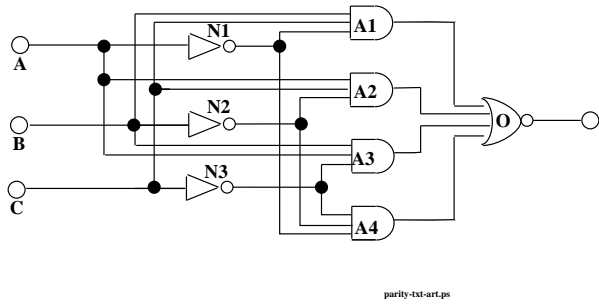

Figure 2: A 3-bit parity circuit is cascaded to obtain an n bit parity circuit.

$[S1(b_{n-1}.A1)]$ $[S1(b_{n-1}.O1)]$ and $[S1(b_{n-1}.A2)]$. $[S1(X2)]$ indicates the diagnostic candidate in which component $X2$ is in mode $S1$ (output stuck-at-1), and the remaining components are functioning correctly. When posed this diagnostic task, the focused Sherlock finds exactly these 5 diagnoses for any n . Moreover, it requires only 7 minimal conflicts (for all $n > 1$). In contrast, with the unfocused GDE the number of conflicts grows rapidly with n (e.g., at $n = 8$ there are 1545 conflicts). Also the CPU time taken to find these 5 diagnoses grows very slowly with n (see Figure 5).

Computationally the techniques of this paper operate by simultaneously limiting the execution of consumers (i.e., the propagation of values through the constraints modeling the components), restricting the ATMS label update algorithms, and controlling candidate generation. Ideas for controlling the execution of consumers are discussed in [5; 6; 11]. Controlling the ATMS itself is discussed in [9; 10; 11]. The unique contribution of this paper is the monolithic most-probable-first diagnostic strategy that fits these pieces together in a novel combination to obtain vastly superior performance on diagnostic tasks.

3 The source of the explosion

GDE's and Sherlock's diagnostic process consists of three processing phases.

Prediction: Use the observations and component models to make predictions.

Conflict recognition: Recognize discrepancies between predictions and observations to construct a set of conflicts, that is, sets of component modes which cannot all hold simultaneously.

Candidate generation: Identify assignments of modes to all the components which explain all the symptoms, that is, not containing any conflicts as subsets. These are the diagnoses.

In GDE and Sherlock this process is performed incrementally in response to every new observation. Nevertheless for each new observation these three steps are performed sequentially.

In diagnosing a large device, each of these three steps exhibits a combinatorial explosion. We analyze a family of different size adders (see Figure 1). Each gate is modeled by

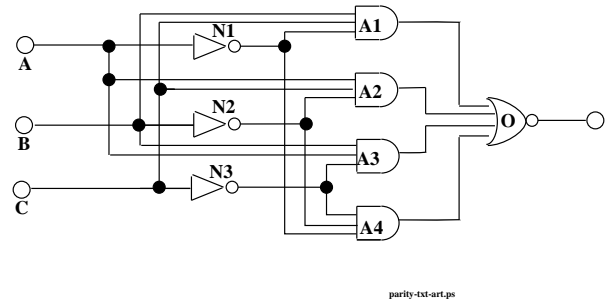

Figure 3: Number of minimal predictions vs. number of gates.

one good mode (G) and three faulty modes: output stuck-at-1 ($S1$), output stuck-at-0 ($S0$) and unknown (U). (Our analysis here focuses on Sherlock because it subsumes GDE.)

The prediction phase is supported by the ATMS and its consumer architecture. Each prediction consists of a specific value for a device variable and a (consistent) conjunction of underlying assumptions (called an *environment*) which, together with the observations, imply that value. In all of our examples each assumption is a behavioral mode of some component, although this restriction is not necessary in general (for example, in [16] assumptions are used to represent time and modeling assumptions). If all the inputs are 0, then the predictions for $b0.Q = 1$ are:

$$S1(b0.X2) \rightarrow b0.Q = 1,$$

$$G(b0.X2) \wedge S1(b0.X1) \rightarrow b0.Q = 1.$$

For example, the second prediction states that if the exclusive-or gate $X2$ of bit 0 is operating correctly and the exclusive-or gate $X1$ has its output stuck at 1, then the output bit of bit 0 is 1. A prediction $E \rightarrow n$ is minimal if there is no other prediction $E' \rightarrow n$ such that $E' \subset E$. The prediction phase finds all minimal predictions.

As every subset of assumptions can lead to a distinct prediction there are typically an exponential number of possible predictions. The ATMS exploits the monotonicity property that if a fact follows from a set of assumptions it follows from every superset as well. Hence, it is only necessary to compute and represent the minimal environments (under subset) for each fact. These are the minimal predictions. Although considering only the minimal predictions leads to great improvements, we see from the data that we do not escape the combinatorial explosion. Figure 3 plots the total number of minimal predictions for all circuit variables vs. the number of gates in the ripple carry adder. This growth curve is typical for the circuits we have looked at.

The next phase of the conventional model-based algorithm, conflict recognition, suffers from the same combinatorial growth as prediction. A conflict is an environment which is inconsistent with the observations. In analogy with prediction, we are only interested in the minimal conflicts. Consider the case where we observe the symptom $bn.Q = 1$ ($bn.Q$ should be 0 because all the adder inputs are 0). Figure 4 plots the the number of minimal conflicts vs. the number of gates in the ripple carry adder.

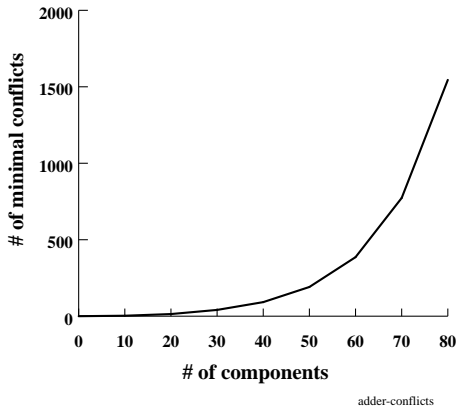

Figure 4: Number of minimal conflicts vs. number of gates.

The candidate generation phase often exhibits combinatorial growth as well. Almost by definition, the number of diagnoses grows exponentially in the number of components. Therefore most earlier approaches to model-based diagnosis find minimal diagnoses. The notion of minimal diagnosis is easily extended to the case where there are fault modes and produces significant savings. Intuitively we say a diagnosis is non-minimal if we can replace any faulty mode with a good mode and still have a diagnosis, or if we can replace the faulty U mode with any other mode and still be a diagnosis. If U is the only fault mode, then this definition is identical to the usual one of minimal diagnosis.

Although devices may have exponentially many minimal diagnoses, this exponential is often avoided in practice. For example, the n -bit adder has $3n - 1$ minimal diagnoses. Of course, this is still not of much help, as 74 minimal diagnoses for a 25-bit ripple carry adder is unreasonable. All but five of these 74 diagnoses are extremely unlikely multiple faults which should not be considered until the more likely (single) faults are eliminated. We saw earlier that if a bit position is symptomatic, then no matter how many bits wide the adder is, there are only five probable diagnoses after observing that $bn.Q = 1$.

The computational observations of this section are predicated on using multiple faulty behavior modes for components. If we were to use the GDE-style models which did not characterize faulty behaviors, then the results would be less explosive. The number of minimal diagnoses vs. circuit size is identical; the plot of predictions vs. circuit size becomes polynomial and the the plot of conflicts vs. circuit size becomes linear. Nevertheless, even a linear number of minimal diagnoses is still unacceptable for our example. The results of this paper thus provide significant computational advantage to both GDE-style and Sherlock-style diagnoses.

4 Focusing

We briefly describe a computational architecture for reining in the combinatorial explosion of all three phases of model-based diagnosis. The conventional architecture requires first completing prediction, then conflict recognition, and finally candidate generation. Within our new architecture all three

processes are intermixed so that the computational effort expended in prediction, conflict recognition and candidate generation are simultaneously minimized. Rather than generating all candidates at once, at the very end — we generate the candidates one at a time (based on the known conflicts), and then focus prediction and conflict recognition only on testing the consistency of the single candidate with respect to new observations.

Candidates are generated in decreasing order of probability, thus candidate generation can be cut off once all the probable candidates have been enumerated — little effort is expended on the overwhelmingly larger set of improbable diagnoses. Note that this presents a bootstrapping problem: generating the candidates in the proper order requires knowing their posterior probabilities. These probabilities are computed from the predictions and conflicts that follow from each candidate. Computing these predictions and conflicts for all candidates would defeat the purpose of the focusing mechanism — since the whole point is to only compute them for the most probable candidates. To solve this “chicken and egg” problem we generate candidates one at a time using the prior probabilities as an estimate of their posterior probabilities. We then perform prediction and conflict recognition on each candidate individually. Finally the strategy estimates the posterior probabilities and the ordering of these candidates based on the information gained. Our experience is that these prior probabilities provide a reasonably accurate estimate, and that only a small amount of effort is wasted pursuing candidates that turn out to be improbable. Once the probable candidates are generated, probe points are proposed that best distinguish among these candidates.

4.1 Focusing candidate generation

The driving intuition behind our framework is to focus the reasoning on what will ultimately be the most probable diagnoses. Instead of estimating the probabilities in some post-processing stage we exploit and incorporate the probabilities from the beginning. The candidate generator does most-probable-first search. Like GDE and Sherlock we determine the posterior probabilities of candidates by Bayes rule:

$$p(C_l | x_i = v_{ik}) = \frac{p(x_i = v_{ik} | C_l)p(C_l)}{p(x_i = v_{ik})}.$$

The prior probability of any candidate C_l is evaluated assuming independence of component failures:

$$p(C_l) = \prod_{m \in C_l} p(m).$$

where $p(m)$ denotes the prior probability of behavior mode m being manifested (i.e., a particular component being in a particular mode).

Conflict recognition is necessary to determine which candidates are eliminated by the observations, i.e., when $p(x_i = v_{ik} | C_l) = 0$. Prediction is necessary to determine which candidates are supported by the evidence, i.e., when $p(x_i = v_{ik} | C_l) = 1$. The objective of our framework is to correctly identify the probability ranking of each diagnosis, but not necessarily establish its absolute probability. Therefore, the

denominator $p(x_i = v_{ik})$ is just a normalization and does not need to be accurately determined to rank candidates.

From Bayes rule we know that the posterior probability of any candidate is bounded above by:

$$p(C_l | x_i = v_{ik}) \leq \frac{p(C_l)}{p(x_i = v_{ik})}.$$

We have incorporated this formula directly into the candidate generator. Our candidate generator performs a co-routining best-first search. The candidate generator returns exactly one candidate at a time. It returns the next most probable candidate based on its prior probability. In addition, the candidate generator avoids candidates subsumed by conflicts that have been encountered thus far.

4.2 Focusing constraint propagation

Our co-routining candidate generator provides the next most probable candidate based solely on its prior (and the conflicts which have been accumulated thus far). We must perform sufficient reasoning on this candidate to correctly establish its posterior probability. In order to do so efficiently we must perform prediction and conflict recognition focused on this candidate alone. Instead of using a conventional ATMS we use a hybrid TMS (HTMS [9]) which has some of the properties of a focused ATMS and some of the properties of a conventional TMS.

The original GDE unfocused engine using a conventional ATMS finds all minimal predictions and conflicts regardless of leading candidates. Our focused algorithm uses the tentative candidates generated by the best-first search to focus its inferences. For each tentative candidate, the HTMS constructs at most one prediction for each circuit quantity and (usually) at most one conflict. This avoids the exponential explosion we see in Figure 3, but critically relies on a method to generate the tentative leading candidates.

5 When to stop generating candidates

Our best-first search is guaranteed to generate candidates in decreasing order of their prior probabilities. If all the leading diagnoses predict the same observations, then we see from Bayes rule that the candidate generator will find candidates in decreasing order of their posterior probabilities. Candidate generation stops when one of the following criteria is met.

1. The best candidate has posterior (estimated) probability greater than k_2 (we usually use $k_2 = 100$) times the prior probability of the next candidate to be returned by the candidate generator.
2. There are $k_1 > 1$ or more candidates. As the overall task usually requires probing, it is often preferable to avoid generating all leading candidates because many of them will be eliminated by the next probe anyway. Usually a good probe can be selected using just a few of the candidates.
3. The sum of the probabilities all the candidates generated exceeds more than k_3 (usually $k_3 = .75$) of the probability mass of all the candidates possible. We approximate

this latter probability mass with an upper bound computed by setting the mass to 1 initially and subtracting from this the probability of every explicitly eliminated candidate.

If diagnoses do not all predict the same observations (this usually occurs when U modes appear in diagnoses), then the relative priors do not establish the relative posteriors. Therefore, our architecture maintains two lists of candidates ordered by their (estimated) posterior probabilities. The first list l_1 contains all candidates whose posterior probability is guaranteed to be greater than the prior of the next candidate which the candidate generator will provide. The second list l_2 contains candidates whose posterior probability is currently less than the prior probability of the next candidate the candidate generator can provide. Thus, during the best-first search, even though no new candidates may be found by the search, candidates may be moved from l_2 to l_1 . The list l_1 is considered the list of leading diagnoses or candidates — l_2 is not used in the stopping criteria. The full paper describes some strategies to better estimate posterior probabilities during search and thus prevent l_2 from becoming large. These are useful primarily in cases where there are multiple U modes and where outputs are measured before inputs, and were not used in any of the examples of this paper.

6 Proposing a new probe

If l_1 contains multiple, differentiable diagnoses, then additional probes need to be made to identify the correct diagnosis. The minimum entropy technique of GDE can be applied without modification using l_1 as the set of diagnoses. The minimum entropy technique is an algorithm based on the presupposition that there are a very large number of diagnoses such that multistep lookahead is unacceptably expensive. In our case there are usually only a handful of leading diagnoses and therefore we simply perform full lookahead (where the costs at the leaves of the decision tree are the logarithm of the current posterior probability of the candidate).

Notice that it is unnecessary to have a distinct test to determine whether the diagnoses in l_1 are distinguishable. If they are not differentiable, then we find no useful probes. In that case, the diagnosis session is complete.

Using the our focused diagnostic engine produces the same leading diagnoses as the unfocused engine but orders of magnitude more efficiently. The only serious penalty incurred by using focusing is that it can propose suboptimal probes. The more diagnoses that are available, the more accurately hypothetical probes can be evaluated. Without additional heuristics, the probing strategy often proposes what intuition would say are suboptimal probes. This occurs because every component which is not faulted in some leading diagnosis is essentially considered unfaulted. As a consequence probes distant from the actually possibly faulty components are often proposed (see [9]). This is suboptimal for two reasons. First, as diagnosis proceeds and candidates are eliminated this probe may be shown to be suboptimal. Second, this generates large conflicts. Therefore, our implementation has a simple heuristic which says that if two probes have equal diagnostic value, then pick that probe point which is nearest a possibly faulty

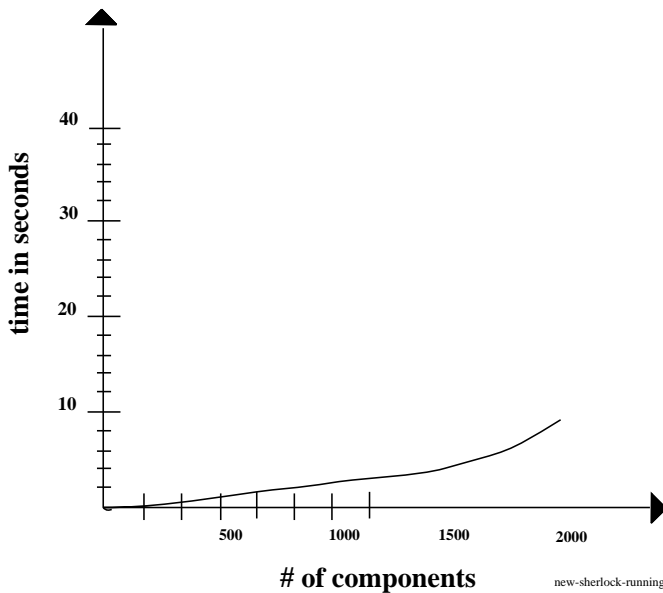

Figure 5: Running time in seconds vs. size in gates (of an adder) on an XL1200

component.

7 Results

The focused diagnostic architecture outlined in this paper improves the performance of model-based diagnosis by orders of magnitude. We can now diagnose devices which were impossible to analyze before. To simplify the explanations, this data was obtained by setting the probabilities of the $S1$ and $S0$ modes low and equal but higher than that of the U modes. Comparable results should be obtained with any reasonable initial probabilities. The diagnostic task for the adder is the same as in the introduction. The diagnostic task for the parity is an input of all 0's and an erroneous output parity.

Our unfocused implementation exceeds 60 seconds (on a Symbolics XL1200) at approximately 50 components (a 10 bit adder). Figure 5 shows that the running time is roughly linear for the focussed algorithm until about 1500 components after which performance begins to degrade. Performance monitoring shows that this non-linear degradation is attributable to our implementation of best-first search.

Although the n -bit adder has $3n - 1$ minimal diagnoses, our algorithm identifies 5 leading diagnoses for each n . For the parity circuit on the other hand the number of leading diagnoses grows slowly with n (always n is the number of input bits).

The following table compares the number of minimal predictions with and without focusing. Column 'G' lists the number of gates in the device. Parity's results come in groups of three because the circuit is constructed in multiples of 3.

n	G	Adder pred's		G	Parity pred's	
		No focus	Focus		No focus	Focus
1	5	47	23	0	0	0
2	10	160	56	8	131	51
3	15	387	76	9	131	59
4	20	831	89	24	12453	222
5	25	1712	102	24	12453	230
6	30	3494	115	24	12453	230
7	35	7153	128	32		330
8	40	14737	141	32		330

The following table compares the number of conflicts with and without using our focused diagnostic architecture.

n	G	Adder conflicts		G	Parity conflicts	
		No focus	Focus		No focus	Focus
1	5	3	3	0	0	0
2	10	14	6	8	13	6
3	15	41	7	9	13	6
4	20	92	7	24	2707	16
5	25	191	7	24	2707	16
6	30	386	7	24	2707	16
7	35	773	7	32		21
8	40	1544	7	32		

In the case of the adder we see that the number of conflicts with focusing is constant in the size of the circuit. In parity the number of minimal conflicts grows very slowly. The two tables show that for both circuits the performance improvement is dramatic. We ran the diagnostic algorithm on a variety of circuits from a standard test suite of circuits [1]. We repeatedly inserted a random fault in each circuit, found a sensitive input vector, and applied our diagnostic engine to find the diagnoses. The tables show the average number of minimal predictions (\bar{P}) and minimal conflicts (\bar{C}). The complexity of our algorithm is roughly proportional to the number of minimal conflicts it finds. Nevertheless, for crude comparison purposes we include the current running times as well. The unfocused GDE results are not included because it is much too slow to diagnose most of these circuits.

circuit	type	G	\bar{P}	\bar{C}	\bar{t}
A500	Adder	5000	6537	7	6
c17	simple logic	7	33	3	.2
c432	priority decoder	160	1255	23	4
c499	ECAT	202	2314	49	10
c880	ALU and control	383	1982	35	8
c1355	ECAT	546	1645	160	131
c1908	ECAT	880	12011	91	62
c2670	ALU and control	1193	4888	47	34
c3540	ALU and control	1669	4100	15	15
c5315	ALU and selector	2307	5923	27	
c7552	ALU and control	3512	16989	172	622

8 Discussion

The performance of the new focused diagnostic algorithm is dramatically better than that of the unfocused algorithms. It completely subsumes our previous algorithms and it is now being used in other research in diagnosis [13; 16].

We are continuing to analyze the algorithm with the goal of improving its overall performance. Our experience raises

some questions and open issues. The averages in the tables obscure the fact that the algorithm does surprisingly poorly for certain symptoms (the unfocused algorithm does even more poorly). If the circuit contains a great deal of reconvergent fanout, a significant amount of redundancy, and the particular input vector and fault cause these to be manifest, then the algorithm performs relatively poorly. We also used a fault simulator to identify which faults were consistent with the symptoms. In some cases, particularly in *c7552*, this strategy outperforms our algorithm. If the sole goal were the identification of single-fault diagnoses, then probably the most efficient overall algorithm would be to use the focused diagnostic engine to find the first few conflicts, and then switch to a conventional simulator to test the remaining single fault candidates. Of course, such simulators do not directly extend to multiple faults, probabilities, minimum entropy techniques, explanations, non-digital devices, etc.

As circuit *c7552* provoked so many of the cases of poor performance, we monitored the performance of the algorithm on it extensively. We determined that most of the time was spent waiting for the disk to page in HTMS data structures. The working set of the algorithm significantly exceeded the amount of real memory available (6 MW). We are currently studying algorithmic variations to reduce the working set requirements of the algorithm.

9 Acknowledgments

I thank Brian C. Williams with whom I started this work. Discussions with Daniel G. Bobrow, David Goldstone, Olivier Raiman, Mark Shirley and Peter Struss helped clarify the ideas and presentation.

References

- [1] Brglez, F., and H. Fujiwara, A neutral netlist of 10 combinational benchmark circuits and a target translator in FORTRAN, distributed on a tape to participants of the Special Session on ATPG and Fault Simulation, Int. Symposium on Circuits and Systems, June 1985; partially characterized in F. Brglez, P. Pownall, and R. Hum, Accelerated ATPG and fault grading via testability analysis, *Proc. IEEE Int. Symposium on Circuits and Systems*, (June, 1985) 695–698.
- [2] Davis, R., and Hamscher, W., Model-based reasoning: Troubleshooting, in *Exploring artificial intelligence*, edited by H.E. Shrobe and the American Association for Artificial Intelligence, (Morgan Kaufman, 1988), 297–346.
- [3] de Kleer, J., An assumption-based truth maintenance system, *Artificial Intelligence* **28** (1986) 127–162. Also in *Readings in NonMonotonic Reasoning*, edited by Matthew L. Ginsberg, (Morgan Kaufman, 1987), 280–297.
- [4] de Kleer, J., Extending the ATMS, *Artificial Intelligence* **28** (1986) 163–196.
- [5] de Kleer, J., Problem solving with the ATMS, *Artificial Intelligence* **28** (1986) 197–224.
- [6] de Kleer, J. and Williams, B.C., Diagnosing multiple faults, *Artificial Intelligence* **32** (1987) 97–130. Also in *Readings in NonMonotonic Reasoning*, edited by Matthew L. Ginsberg, (Morgan Kaufman, 1987), 372–388.
- [7] de Kleer, J. and Williams, B.C., Diagnosis with behavioral modes, in: *Proceedings IJCAI-89*, Detroit, MI (1989) 104–109.
- [8] de Kleer, J., Using crude probability estimates to guide diagnosis, *Artificial Intelligence* **45** (1990) 381–391.
- [9] de Kleer, J., A hybrid TMS, submitted for publication, 1990.
- [10] Dressler, O., and Farquhar, A., Focusing ATMS-based problem solvers, Siemens Report INF-2-ARM 13, 1989.
- [11] Forbus, K.D., de Kleer, J., Focusing the ATMS, *Proceedings AAAI-88*, Saint Paul, MN (August 1988), 193–198.
- [12] Genesereth, M.R., The use of design descriptions in automated diagnosis, *Artificial Intelligence* **24** (1984) 411–436.
- [13] Goldstone, D.J., Controlling inequality reasoning in a TMS-based analog diagnosis system, *Proceedings AAAI-91*, Anaheim, CA, (August, 1991) 512–517.
- [14] Hamscher, W.C., Model-based troubleshooting of digital systems, Artificial Intelligence Laboratory, TR-1074, Cambridge: M.I.T., 1988.
- [15] Raiman, O., Diagnosis as a trial: The alibi principle, IBM Scientific Center, 1989.
- [16] Raiman, O., de Kleer, J., Shirley, M.H., and Saraswat, V., Characterizing Non-Intermittency, *Proceedings AAAI-91*, Anaheim, CA, (August, 1991) 849–854.
- [17] Shirley, M.H., *Generating Tests By Exploiting Designed Behavior*. PhD thesis, MIT, January 1989.
- [18] Struss, P., Extensions to ATMS-based Diagnosis, in: J.S. Gero (ed.), *Artificial Intelligence in Engineering: Diagnosis and Learning*, Southampton, 1988.
- [19] Struss, P., and Dressler, O., “Physical negation” — Integrating fault models into the general diagnostic engine, in: *Proceedings IJCAI-89* Detroit, MI (1989) 1318–1323.