

Resource-Efficient Encoding Communication and Fusion in Wireless Networks of Sensors and Actuators

Haralabos Papadopoulos
Electrical and Computer Engineering
University of Maryland, College Park

Wireless Sensor Networks

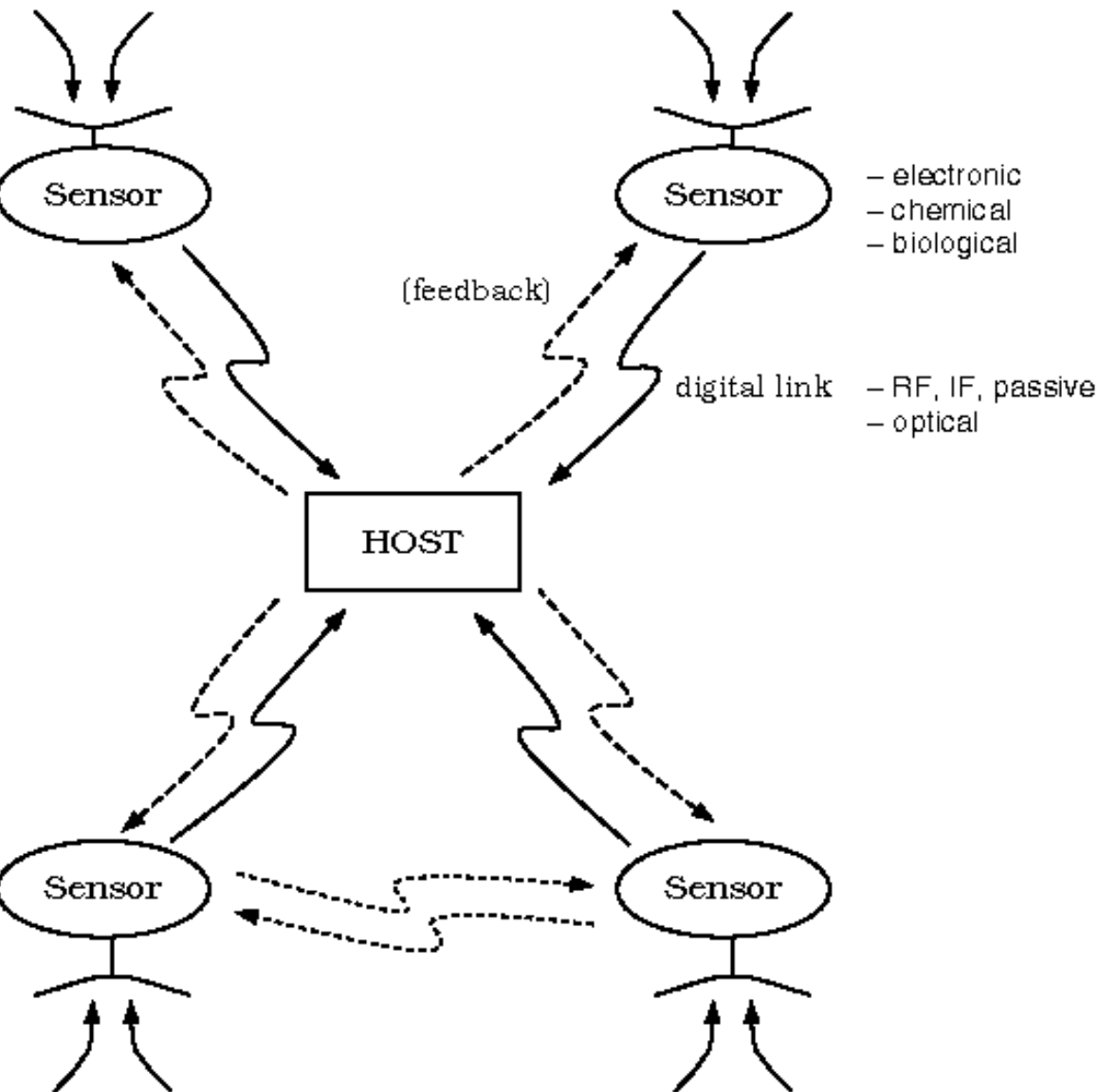

Sensor networks for

surveillance and
monitoring

chemical/biological
hazard detection

earth observation

smart spaces, safe cities

Challenges

- Communication over *fading* channels
- Limited *bandwidth* and processing *power* per sensor
- Inherent limitations in sensor *dynamic range* and *resolution*
- *Latency*-critical information transfer
- *Heterogeneous* networks
- *Spatial* and *temporal variability* in sensor resources and sensor data fidelity

Minimal-Delay Encoding Communication and Fusion

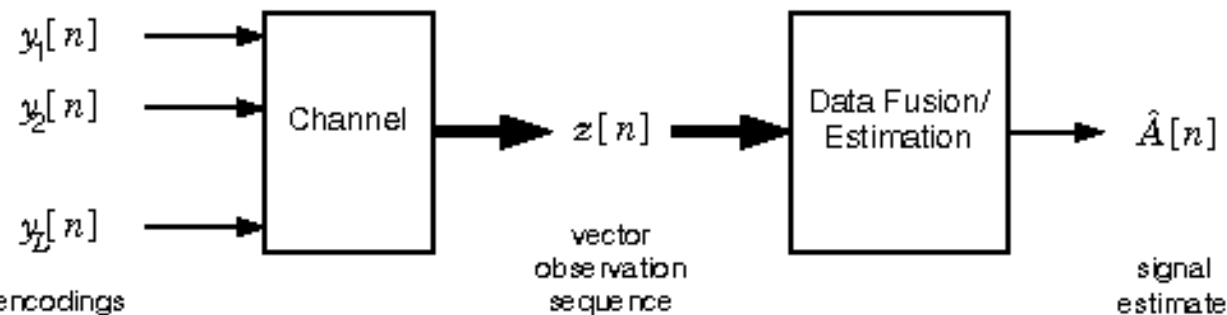
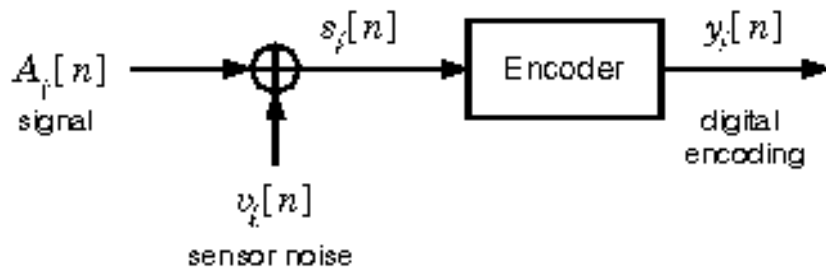

Algorithms for

- signal encoding at sensors
- communication of encodings to host
- fusion of received encodings at host

Related Work

- Coding theorem for noisy sources
[Berger 1971], [Wolf & Ziv 1970]
- Encoding/reconstruction algorithms (noisy sources)
[Ephraim & Gray 1988]
- The CEO problem
[Berger 1996]

Methodology

Hierarchy of algorithms that

- are progressively refinable
- trade fusion performance for sensor processing complexity
- readily scale with the number of sensors and bandwidth
- accommodate large scale data fusion

Fusion over Discrete Memoryless Channels

Setting

- state-space model based signal representation
- orthogonal power-controlled multisensor communication over slowly-varying flat fading channels
- need for minimal delay in communicating measurements

Fusion over Binary Symmetric Channels

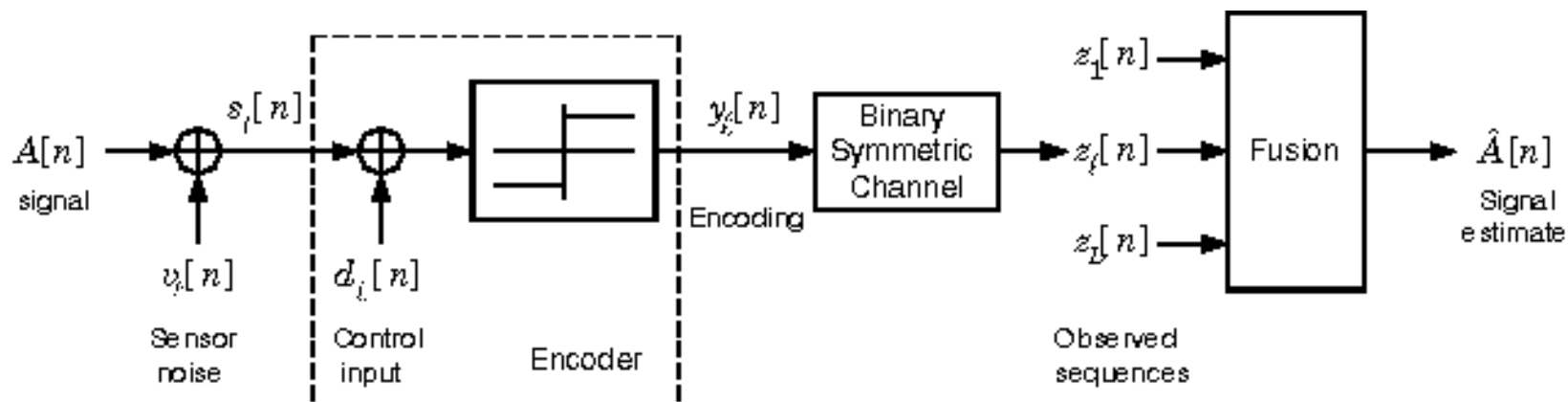

- Encoder
 - additive control input followed by scalar quantizer
- Fusion
 - host obtains signal estimate via received encodings

Estimation of AR(1) Process

- Encoder design:
 - combination of *pseudorandom* and *feedback-based* control
- Fusion method:
 - spatial fusion to produce intermediate data sequence
 - extended Kalman filter with intermediate sequence as measurements

Performance Metrics

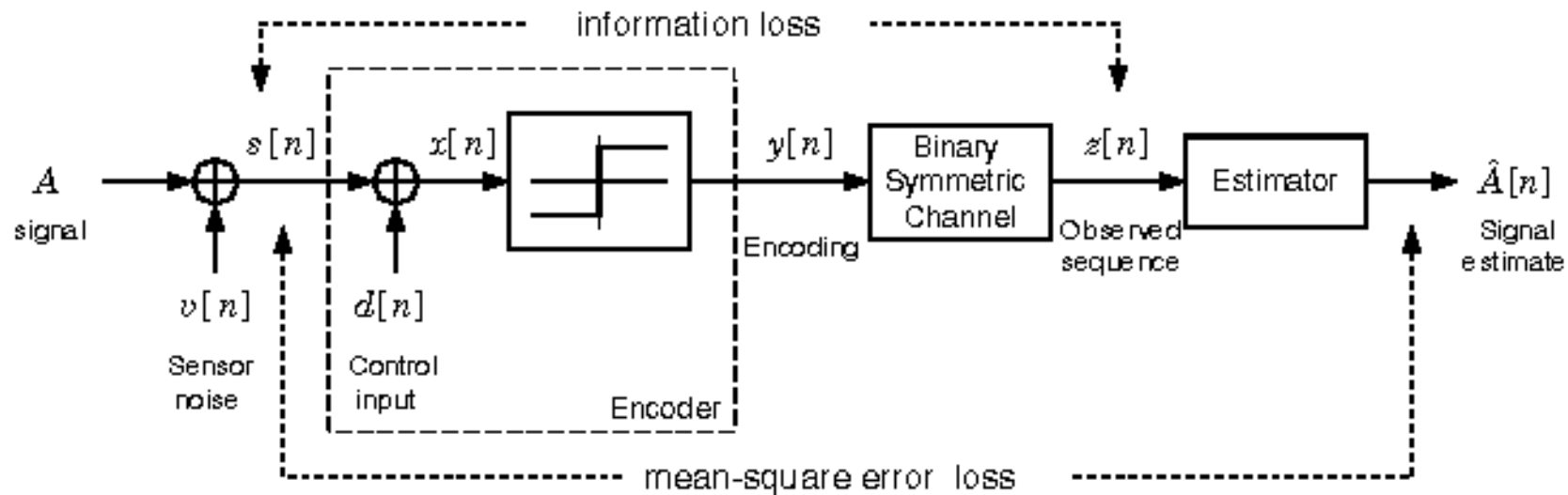

- **Information loss:** performance loss from using received encodings (instead of sensor measurements) for fusion
- **MSE loss:** fusion performance loss of overall system compared to best system operating on sensor measurements

MSE Performance vs. Signal Bandwidth

- Example: 100 sensors, BSC BER=0.05

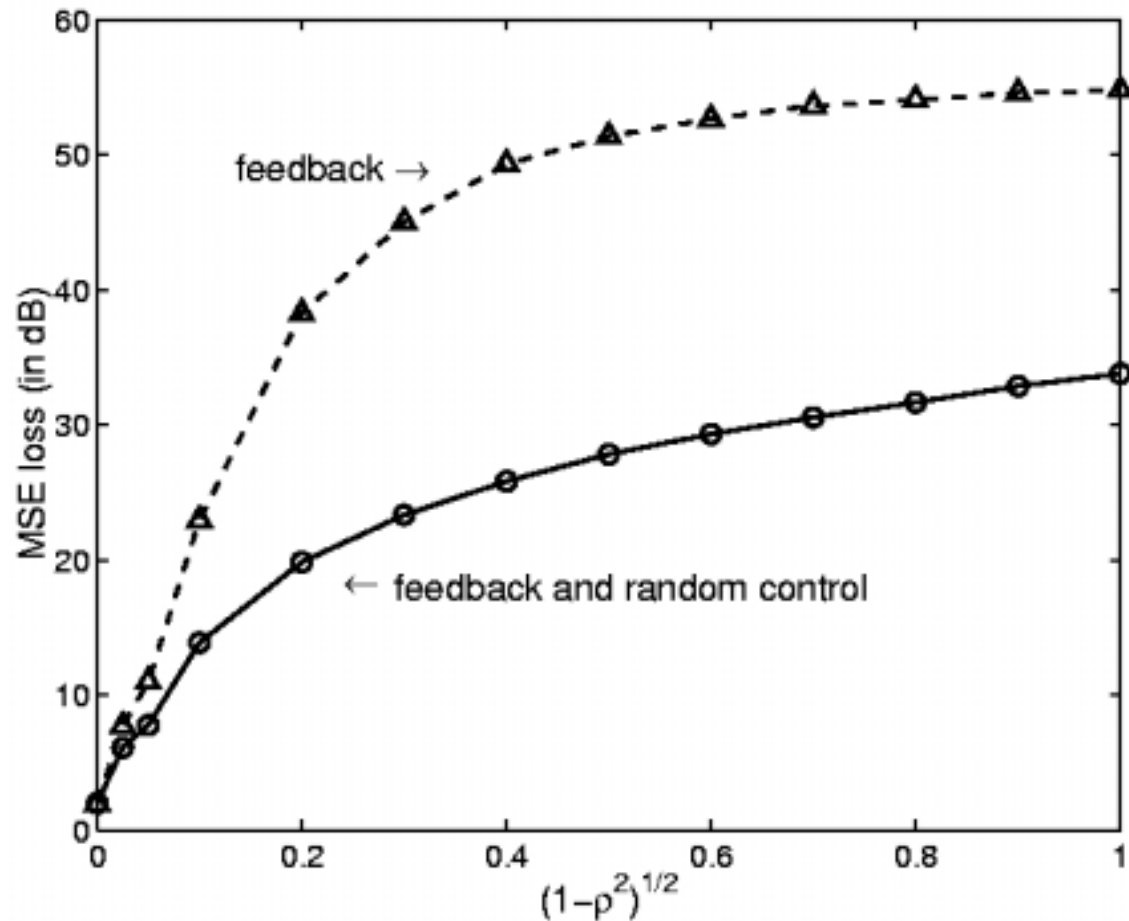

Remarks

- Feedback is effective in improving over decentralized performance
- Encoding *running estimates* at each sensor
 - yields *improved fusion characteristics*
 - at expense of *higher sensor encoder complexity*
- Approaches have been extended over fading channels with no power control
- Hierarchy of algorithms with performance-complexity tradeoffs

Communication and Fusion over Fading Channels

- Setting
 - sensors communicate over shared bandwidth
- Cases
 - sensors may/may not have channel state information available
 - a lot vs. scarce bandwidth per sensor
 - synchronous vs. asynchronous multisensor communication
 - partial vs. no information exchange among collocated sensors

Communication and Fusion over Fading Channels

- Abundant bandwidth (\geq "1 slot/sensor meas."), orthogonal multisensor signaling
 - detection of individual sensor encodings
 - fusion of detected encodings
 - ➔ both spatial averaging and diversity benefits
- Limited bandwidth (*e.g.* "1 slot/ L sensor meas."), perfect channel side info at each sensor
 - beamforming and fusion
 - ➔ both spatial averaging and diversity benefits

Methodology/Objectives

- Multiuser cooperative signaling to achieve
 - (transmit antenna) diversity benefits
 - fusion benefits
- as a function of
 - available bandwidth per sensor
 - available channel information to sensor
 - allowed processing delay
- Schemes that scale with
 - available bandwidth
 - number of sensors, and transmit/receive antennae

Wireless Relays (*cont.*)

Methodology/Objectives:

- Power-optimized relaying strategies as a function of
 - bandwidth expansion
 - available information at transmit sensors/relays
 - allowed processing delays
- Centralized vs. decentralized relaying algorithms